



## ESE Power Generator

TRANSLATION OF THE ORIGINAL OPERATING MANUAL



**ESE 2100 i**

**Article-No. 110 008**

**Manufacturer**      **ENDRESS Elektrogerätebau GmbH**  
Neckartenzlinger Str. 39  
D-72658 Bempflingen, Germany

Tel: + 49 (0) 71 23 / 9737 - 0  
Fax: + 49 (0) 71 23 / 9737 – 50  
Email: [info@endress-stromerzeuger.de](mailto:info@endress-stromerzeuger.de)  
www: <http://www.endress-stromerzeuger.de>

**Document number / version**    E136690 / i02

**Publication date**            May 2022

**Copyright**                    © 2022 ENDRESS Elektrogerätebau GmbH

This documentation and parts thereof are subject to copyright. Any use or modification beyond the restrictions of the Copyright Act is forbidden and subject to penalty without the consent of ENDRESS Elektrogerätebau GmbH.

This applies in particular to copies, translations, microfilming, as well as storage and processing in electronic systems.

**Notes on printing**            All descriptions, technical details and illustrations refer to the version of the generator for printing.

We reserve the right to make modifications in terms of ongoing technical development. This operating manual does not include technical modifications that occurred after printing.

The colours in this operating manual do not always comply completely with the actual designs due to technical printing reasons.

---

## Table of Contents

<b>1</b>	<b>Directories</b> .....	<b>5</b>
<b>2</b>	<b>About this manual</b> .....	<b>6</b>
2.1	Constituent parts of the documentation .....	6
2.2	Using this operating manual .....	6
<b>3</b>	<b>Product identification</b> .....	<b>9</b>
3.1	Welcome to ENDRESS! .....	9
3.2	Your product .....	9
3.2.1	A device description and intended use .....	9
3.2.2	Foreseeable misuse .....	10
3.3	included in delivery .....	12
3.4	Labels on the generator .....	13
<b>4</b>	<b>For your safety</b> .....	<b>15</b>
4.1	Safety symbols .....	15
4.2	General safety instructions .....	17
4.3	Residual risks .....	17
4.4	Authorised operating personnel – qualifications and obligations .....	22
<b>5</b>	<b>Checking the electrical safety</b> .....	<b>23</b>
<b>6</b>	<b>Description of the device</b> .....	<b>24</b>
6.1	Views .....	24
6.2	Important components on the control and maintenance side .....	25
6.3	Important components on the start and exhaust gas side .....	26
6.4	Control panel components .....	27
<b>7</b>	<b>Commissioning</b> .....	<b>28</b>
7.1	Transporting and preparing your generator .....	28
7.2	Refuelling your generator .....	29
7.3	Starting the generator .....	30
7.4	Connection of power consuming equipment .....	32
7.5	Parallel working using two generators .....	34
7.6	Turning off your power generator .....	35
<b>8</b>	<b>The device in-use</b> .....	<b>37</b>
8.1	ECOtronic (idle down) .....	37
8.2	Charging the batteries .....	38
<b>9</b>	<b>Maintenance</b> .....	<b>39</b>
9.1	Maintenance plan .....	39
9.2	Maintenance work .....	40
9.3	Engine oil .....	40
9.3.1	Checking the oil level .....	40
9.3.2	Refilling with engine oil .....	42
9.3.3	Changing the engine oil .....	43
9.4	Maintenance of the air filter .....	44
9.5	Spark plug maintenance .....	45

9.6	Cleaning the spark screen . . . . .	47
9.7	Cleaning the power generator . . . . .	48
<b>10</b>	<b>Storage . . . . .</b>	<b>49</b>
<b>11</b>	<b>Disposal . . . . .</b>	<b>50</b>
<b>12</b>	<b>Troubleshooting . . . . .</b>	<b>51</b>
<b>13</b>	<b>Technical data . . . . .</b>	<b>54</b>
<b>14</b>	<b>CE declaration . . . . .</b>	<b>55</b>
<b>15</b>	<b>Replacement parts . . . . .</b>	<b>56</b>
	<b>Keyword index . . . . .</b>	<b>59</b>

# 1 Directories

## 1.1 List of illustrations

Fig. 3-1	Example of a type plate	.9
Fig. 3-2	Scope of delivery (similar to the illustration)	.12
Fig. 3-3	Labels on the device	.13
Fig. 6-1	Views of the generator	.24
Fig. 6-2	Maintenance and control side components	.25
Fig. 6-3	Exhaust gas and start side components	.26
Fig. 6-4	Components on the control panel	.27
Fig. 7-1	Starting the generator	.31
Fig. 9-1	Checking and changing engine oil	.41
Fig. 9-2	Optimal engine oil level	.42
Fig. 9-3	Air filter behind the maintenance flap (removed)	.44
Fig. 9-4	Remove spark plug	.46
Fig. 9-5	Checking the spark plug	.47
Fig. 15-1	Spare parts over <a href="http://endressparts.com">endressparts.com</a>	.56

## 1.2 List of tables

Tab. 3-1	Labels on the device	.14
Tab. 5-1	Recommended test intervals	.23
Tab. 9-1	Generator maintenance plan	.40
Tab. 12-1	Troubleshooting	.52
Tab. 13-1	Power generator technical data	.54

## 2 About this manual

We would like to explain to you the safe and correct use of your generator in the best possible way through this operating manual. To do this we have oriented ourselves to the new European standard DIN EN 82079-1 for preparing the user manuals.

It is absolutely essential for safe and appropriate use that you read through this manual very carefully and understand it before using the device for the first time.

Your observance of it creates the foundation for,

- avoiding dangers for yourself and others,
- reducing repair costs and downtimes as well as
- increasing the reliability and service life of the generator.

Not only this manual but also the laws, regulations, guidelines, and standards applicable in the country of use must be observed.

This document only describes the safe operation of the generator when used as a complete unit. The following also includes detailed technical operating instructions that are binding with regard to using the device's specific components.

This documentation and also the product described in it are subject to a continuous improvement process. In doing this we ensure that the full product is compliant with the current safety requirements and the current state-of-the-art. The respective most up to date language version of the operating manual and the original operating manual can be found on our website

[www.endressparts.com](http://www.endressparts.com)

### 2.1 Constituent parts of the documentation

Apart from these operating instructions, the following documents are needed to ensure that you have the all of the documentation for your device:

- EU Declaration of Conformity



#### **NOTICE!**

**The complete documentation is an integral part of the device and you must adhere to it.**

- ▶ All of the integral parts of the documentation must always be accessible to the operating personnel and they should be kept with the device.

### 2.2 Using this operating manual

**In order to increase the legibility, comprehensibility and transparency of the document, certain information is highlighted or identified according to a uniform system. The following particularly belong in this category:**

#### ***signs warning a bout dangers to life and limb***

Safety and warning notices are necessary at all locations where there is potential danger from the device which cannot be eliminated by design or operational measures. We restricted ourselves to the permitted minimum in order to place the required distinctive warning notices at the correct point in time without impairing the legibility and comprehensibility of the operating manual. This is according to the regulations contained in the international standard DIN ISO 3864 describes a fixed rule for all safety and warning notices, as shown in the following example.

**Examples:**

Signal Word



Hazard Type

**Electrical voltage**

Hazard Consequence

Risk of suffering potentially deadly electrocution by touching live parts

▶ Hazard Avoidance

- ▶ Only use undamaged connecting lines
- ▶ Avoid all damp / wetness when connecting consumers
- ▶ Never operate the power generator with an opened control panel

The previously mentioned standard classifies the safety risks into different hazard potentials. It is essential that you read the information in Chapter 4 in order to understand and avoid any dangers to health or life.

**Safety symbols**



These warning notices are usually used in a safety symbol which also emphasises the type of danger; see next example. A list of the safety symbols used in this operating manual can be found in Chapter 4.1. The safety symbols never stand alone.

**Notices on avoidance of damage to the device**

According to DIN ISO 3864, notices that warn against false operation and possible damage to the device or to the equipment used should be clearly distinguishable from previously named warning notices in as far there is no danger to health. An example of such a notice can be seen here:

Signal Word



Type and Consequence of Improper Use

**Use of wrong or outdated fuel damages or destroys the engine.**

▶ Intended Use

- ▶ Only use approved fuel.
- ▶ Observe the shelf life of the fuel according to the supplier.
- ▶ Observe the Operating manual from the engine manufacturer

**Symbols and formatting in the text**

In order to increase the legibility, comprehensibility and transparency of the document, various information and activities are awarded uniformly repeating bullets or formatting. The following example shows presentation of a sequence of actions with established work steps:

**Example:**

- ✓ Prerequisites that must be fulfilled before starting any sequence of actions
- 1. Action steps according to a fixed sequence.
- 2. The action steps must be fully completed.  
*Interim result of an action step sequence*
- 3. The sequence must be observed.

*Results of the actions that should be realised after completing the sequence of action steps.*



**Additional notices for operation or for function of a unit are marked with the adjacent symbol.**



**NOTICE!**

The adjacent symbol is situated anywhere where the supplier documentation must be read and observed and refers to,

- ▶ appropriate information,
- ▶ tasks or
- ▶ action steps.

---

References to details and components in figures are made with blue bordered position numbers in the text such as the example of CE signs on the type plate demonstrates, see Fig. 3-1 .

### 3 Product identification

#### 3.1 Welcome to ENDRESS!

We are pleased that you have made the decision to purchase a ENDRESS power generator. You have purchased a high-performance product into which we have embodied decades of our experience and have integrated many functions oriented on daily use. Through careful selection of high quality components and materials in combination with the proverbial Swabian engineering performance you have in your possession a device which will operate reliably for many years, also under the hardest of operating conditions.

#### 3.2 Your product

**Customer service**

In order to precisely identify your device there is a type plate attached to the Generators (see Fig. 3-3 ), which includes details about the device designation and "S/N" serial number. If you have any questions about device details, functions or notices concerning operation, please contact our

**Customer service: Tel. +49 (0)7123 9737-44**

**Email: [service@endress-stromerzeuger.de](mailto:service@endress-stromerzeuger.de)**

You will find competent contact persons there, also concerning original spare parts and wear parts. (see also Chapter 15 )

**Type plate**

The type plate shown below is a representation of the adhesive label placed on the device. Please be prepared, when contacting our service team, to assist us in exactly identifying your device. Refer to your generator's operating instructions for further information about finding the type plate.







		<b>ENDRESS Elektrogerätebau GmbH</b> Neckartenzlinger Strasse 39 D-72658 Bempflingen		
		ESE 		
		ISO 8528		
Sr/Pr kVA/kW	(PRP G1)	6.6/5.3	S/N	 / 11
Ur	3~/1~	400/230	fr	50
Ir	3~/1~	8.7/17.4	cos phi	0,8
IP(Gen.)		54	nr	3000 min <sup>1</sup>
hr		100	Tr	25 °C
Mfg		Okt.18	m	150

Fig. 3-1 Example of a type plate

#### 3.2.1 A device description and intended use

Your generator is a mobile power source that makes electricity available for operating commercially available electrical devices (referred to below as consumers) with 230 V AC voltage.

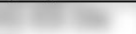
Your generator consists of an inverter generator driven by an internal combustion engine that it is firmly bolted on. This aggregate unit is mounted elastically with a vibration damper producing few vibrations in a protective and sound dampening housing.

The power generator is a mobile electrical device designed for use with an individual electrical consumer (according to VDE 100, Part 551). A splash-proof protective contact socket with nominal voltage of 230 V / 50 Hz 1~ supplies the power (see Fig. 6-4 ).

The generator is not to be connected up to other energy distribution systems (e.g. public power supply) or to other energy generation systems (e.g. other generators, solar plant, etc.).

The stability and quality of the generated voltage is achieved electronically by the inverter.

The generator is only to be used outdoors within the indicated voltage, output, and nominal RPM ranges (see type plate).

The generator is not to be used in explosion-prone environments.

The generator is not to be used in environments where there is a risk of fire.

The generator must be operated according to the specifications in the technical documentation.

Every inappropriate use or all activities on the generator which are not described in these instructions is forbidden misuse outside the legally defined limits of liability of the manufacturer.

### 3.2.2 Foreseeable misuse

**Apart from the description of appropriate use, the lawmaker also requires concrete references to the results of “reasonably foreseeable misuse“. In a case of incorrect use or inappropriate handling of the generator the manufacturer's EU Declaration of Conformity, and automatically thereby also the operating licence, are nullified. For products with a manufacturer's warranty the manufacturer will reject any claims made under warranty for damages which were caused by misuse and its direct as well as indirect consequences.**

In particular unauthorised misapplications include:

- operation of the generator takes place without valid checks for
  - electrical safety
  - checking that the stipulated servicing and maintenance work has been done
- operation of the generator taking place without the protective equipment installed by the manufacturer
- constructional or electrical modifications were made to the generator
- software was modified or changes were made to the generator's factory settings
- use of the generator by inadequately instructed operating personnel

Furthermore at all costs avoid the following Misuses:

- Never refuel the generator's own tank when the engine is running. The vibrations and strong exhaust streams during operation can lead to fuel spillage. This leads to an increased risk of explosion and fire and therefore danger to operating personnel, the environment and the device.
- Never refuel the generator's own tank when it is hot. Overflowing fuel and exhaust fuel vapours can ignite on hot parts of the device.
- Never open the generator's tank cover whilst it is running or if it is hot. Overflowing hot fuel and escaping fuel vapours can ignite on the device's hot parts.

- The generator is never to be connected up to another energy distribution system (e.g. public power supply) or to other power generating systems (e.g. other generators, solar plants, etc.). To start with this is usually not permitted by . In both cases this will inevitably lead to severe damage and possibly also severe injury.
- Never place the generator in explosion-prone environments. The individual components of the generator are not designed to be EX-protected.
- Never operate the generator in rooms, narrow pits or vehicles. The combustion exhaust gases contain poisonous substances including the odourless but deadly gas carbon monoxide (CO) which, when breathed in, can accumulate in cases of poor air circulation to reach deadly concentrations. Also a lack of fresh air circulation leads to overheating and possible damage to the generator right through to destruction.
- For the same reasons of risk, never divert exhaust gases for the purposes of heating rooms or vehicles.
- Never clean the generator with the aid of a high pressure cleaner or a strong jet of water.
- Never allow water to find its way inside the generator. Never pour water over the generator and never clean it using a water hose or a high pressure cleaner.
- Never operate the generator in any area where it could be flooded by high water or any other events. The device's protection class (see Chapter 13 ) allows operation with spray water, however not in the case of floods.

### 3.3 included in delivery

Apart from the technical documentation mentioned in Chapter 2.1 the following articles are also Scope of delivery of your generator:

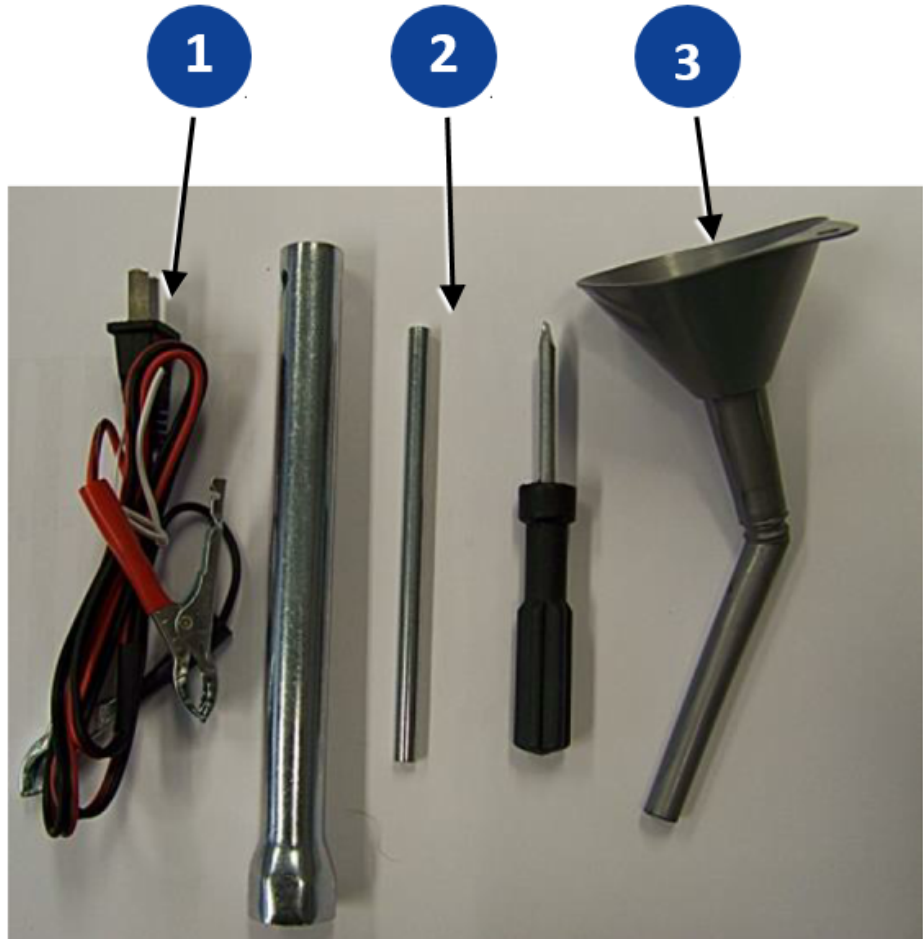

Fig. 3-2 Scope of delivery (similar to the illustration)



Item	Name
①	Battery charging cable
②	Tool set
③	Filling funnel for changing oil



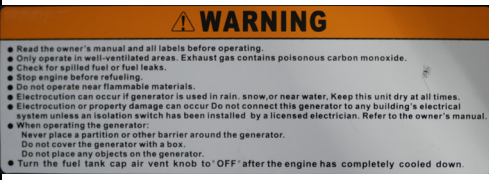
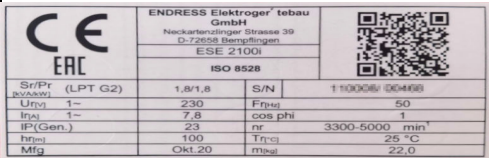

### 3.4 Labels on the generator

An important part of the operating manual is in the form of labelling and notices on your generator. This labels must not be removed and must always be maintained in a legible condition. In the event of damage, new labels can be ordered from our customer service team. The following Figs and tables show the stipulated attachment points and give a brief explanation of the labels.



Fig. 3-3 Labels on the device

Item	Label	Meaning
1		General hazard warning relating to the unit
2		Type plate
3		Warning symbol Danger of suffocation

Item	Label	Meaning
4		Warning symbol Hot surfaces
5		Warning No open fire on the generator
6		Mandatory signs Read the operating manual
7		Earthing information

Tab. 3-1 Labels on the device

## 4 For your safety

The following chapter describes basic Safety instructions for safe operation of your generator. Your device is a very high-performance electrical machine which is potentially dangerous when operated if it has not been installed, commissioned, used, serviced and repaired according to the operating manual. If necessary, the operating manual will also include different supplements that depend on the country of use, in addition to the present one.

Operation, use, servicing as well as any work with or on the generator is therefore only permitted by such persons who have read this chapter and have put its provisions into practice!

Concrete warning notices can also be found regarding basic safety instructions further on in this operating manual. These are always placed in an explanatory text immediately before the description of work steps which can be dangerous if the warning notice is not observed. Read the following sections for correct and rapid understanding of these safety and warning notices. They describe their systematic structure as well as the meaning of markings and symbols.

### 4.1 Safety symbols

**The safety symbol indicates graphically that a source of danger exists. We use the internationally valid safety symbols from ISO 7010 for rapid and unique classification of the respective dangerous situation. In the following there is a description of the warning symbols used in this operating manual with an explanation about the respective dangerous situations.**



#### Warning of a general hazard

This warning symbol indicates activities where several causes can lead to risks. The concrete danger must be respectively more clearly specified by further notices.



#### Warning of a dangerous electrical voltage

This warning symbol is indicates activities where the danger of electric shock exists, possibly with lethal consequences.



#### Warning of potentially explosive materials

This warning symbol indicates activities where the danger of an explosion exists, possibly with lethal consequences.



#### Warning of toxic substances

This warning symbol indicates activities where a risk of poisoning exists, possibly with lethal consequences.



**Warning of corrosive substances**

This warning symbol indicates activities where a risk of chemical burns to the environment as well as people exists, possibly with lethal consequences.



**Warning of environmentally damaging substances**

This warning symbol indicates activities where a risk of contaminating the environment exists, possibly with catastrophic consequences.



**Warning of hot surfaces**

This warning symbol indicates activities during which there is the danger of burns, possibly with lasting consequences.



**Warning of a suspended load**

This warning symbol indicates activities where the danger of falling loads exists, possibly with lethal consequences.



**Warning of automatically starting machines**

This warning symbol indicates activities where a danger of being injured by self-starting machines exists, possibly with lethal consequences.

## 4.2 General safety instructions

**ENDRESS Generators are designed to operate electrical equipment with appropriate power output requirements. Other uses can lead to severe injury to operating personnel and people nearby. There is also increased risk of damage to the generator and further property damage.**



### **DANGER!**

**Mortal danger due to an electric shock if live parts are touched.**

- ▶ Never operate the device if it is in a damaged condition.
- ▶ Never operate the electrical consumers and connecting cable (power consuming equipment) in a damaged condition.
- ▶ Never feed directly into existing networks that are already connected to a power source (e.g. power supplier, solar plant, etc.).
- ▶ Never operate the device with wet hands.

Most injuries and equipment damage can be avoided if all instructions given in this manual and all instructions attached to the device are followed.

The Generators must not be modified in any way, not even temporarily. This pose a death hazard to operating and deployed personnel and damage to the generator and the consumers being used.

Operating company and Operating personnel are to use the Generators only according to regulations contained in the entire technical documentation (hereinafter referred to as appropriate use).

Every instance of inappropriate use and all activities on the Generators that are not described in this manual are prohibited misuse beyond the legally defined limits of the manufacturer's liability. In return all claims for damages and warranty claims against ENDRESS-Elektrogerätebau GmbH that are associated with misuse are null and void.

## 4.3 Residual risks

**As a manufacturer of EU-compliant machines, ENDRESS make great efforts to create designs which already eliminate possible risk potentials at the design stage. If this is not possible without significantly impairing the functions of a device, we implement suitable protective measures protect the user from injury.**

**If there are still some residual risks associated with working with the device, we clearly advise the user about these sources of danger, possible consequences as well as measures to avoid such dangers.**

The residual dangers were analyzed and Residual dangers identified during the development and design of your Generators by means of a danger analysis according to DIN EN 60204, DIN EN ISO 12100 and DIN EN ISO 8528-13.

References to general sources of danger can be found in chapters 4 and 5 . From Chapter 6 one can find concrete warning notices placed before every action step which represents a residual risk.

**The exact structure and contents of warning notices are defined in the ISO 3864 series of standards and follow an established identification marking required to immediately be able to estimate the degree of the respective danger. Exactly impress upon yourself the identification marking of the**

four different danger levels in order to be able to reliably assess the dangers associated with the individual operating states and action steps when reading the operating manual.

 **DANGER!**

**DANGER** describes a danger which represents a high level of risk, which can lead to death or severe injuries, when not avoided.

- ▶ The individual points provide instructions and
- ▶ notices as aids to avoid the danger
- ▶ or to reduce the risk to an acceptable level.

 **WARNING!**

**WARNING** describes a danger which represents a medium level of risk, which can lead to death or severe injuries, when not avoided.

- ▶ The individual points provide instructions and
- ▶ notices as aids to avoid the danger
- ▶ or to reduce the risk to an acceptable level.

 **CAUTION!**

**CAUTION** describes a danger which represents a low level of risk, which can lead to minor or medium level injuries when not avoided.

- ▶ The individual points provide instructions and
- ▶ notices as aids to avoid the danger
- ▶ or to reduce the risk to an acceptable level.

**NOTICE!**

**ATTENTION!** describes a situation or action that might result in damage to equipment and/or malfunctions if it is not prevented.

- ▶ The individual points provide instructions and notices
- ▶ as an aid to avoid or prevent damage to equipment.



**DANGER!**

**Mortal danger due to an electric shock if live parts are touched.**

- ▶ Never operate the device if it is in a damaged condition.
- ▶ Never operate the electrical consumers and connecting cable (power consuming equipment) in a damaged condition.
- ▶ Never feed directly into existing networks that are already connected to a power source (e.g. power supplier, solar plant, etc.).
- ▶ Never operate the device with wet hands.



**DANGER!**

**Engine exhaust gases contain poisonous and partially invisible gases such as carbon monoxide (CO) and carbon dioxide (CO<sub>2</sub>).**

Risk of death due to poisoning or asphyxiation.

- ▶ Ensure that there is good ventilation during the whole period of operation.
- ▶ Only operate the generator in the open.
- ▶ Never direct the exhaust gases into rooms or pits.



**DANGER!**

**Danger of severe or mortal injuries being incurred from falling loads.**

- ▶ Never stand under or close to a suspended load, also not to provide assistance.
- ▶ Ensure that there is no person in the area of swivel of the lifting device.
- ▶ Use all suitable measures to prevent the suspended load from swaying.



**DANGER!**

**Leaking engine oil and fuel can burn or explode.**

A risk of suffering severe even deadly burns.

- ▶ Prevent engine oil or fuel from leaking out.
- ▶ Never open the tank cover during operation or when it is hot.
- ▶ Remove leaked operating fluids immediately and appropriately.
- ▶ Never use an additional starting aid.
- ▶ Smoking, naked flames and sparks are forbidden.



**DANGER!**

**Hot parts can ignite flammable and explosive materials.**

A risk of suffering severe even deadly burns.

- ▶ Never operate the generator in the vicinity of combustible or flammable materials.
- ▶ Never operate the generator in an environment prone to an explosion.

**WARNING!**

**There is a risk of explosion and fire in the case of inappropriate handling and spark development when working with the battery.**

Danger from spraying sulphuric acid. Danger of suffering severe even deadly burns and chemical burns. Danger of being blinded.



- ▶ Never lay conductive parts on the battery.
- ▶ Flames, sparks, an open light and smoking are prohibited.
- ▶ Avoid sparks when handling cables and electrical devices, as well as electrostatic discharge.
- ▶ Avoid short-circuits.
- ▶ Wear acid-resistant protective clothing.

**WARNING!**

**Escaping corrosive acid fumes or sulphuric acid during and after the charging process. A risk of suffering severe or even fatal burns.**

- ▶ Only work with acid-resistant protective equipment.
- ▶ Clean surfaces covered in acid immediately using adequate amounts of water.
- ▶ Only recharge the battery in a well ventilated environment.

**CAUTION!**

**Certain surfaces on the device can get very hot whilst it is running.**

Risk of burns

- ▶ Never touch any engine parts (in particular the exhaust system) for a few minutes after ceasing operation.
- ▶ Always leave hot engine parts to cool down before touching them.

**CAUTION!**

**A high device weight. Risk of crushing from improper handling during operation or transport.**



- ▶ Only lift the generator with the aid of all handles provided or by using a suitable hoist.
- ▶ During transport on vehicles, ensure that there is the prescribed load securing in place.
- ▶ With it in a raised condition, never come close to or stand under the generator.

**NOTICE!**

**Leaking engine oil and operating fluids can contaminate the soil and groundwater.**

- ▶ Ensure that the generator is transported horizontally and mounted.
- ▶ Make all efforts, at all costs, to prevent escaping of operating fluids.
- ▶ Dispose of contaminated soil immediately and according to regulations.

**NOTICE!****Use of wrong or outdated fuel damages or destroys the engine.**

- ▶ Only use the fuel listed in the technical data (Tab. 13-1 ).
  - ▶ Abide by the fuel release instructions given in any documentation that might have been provided by the engine manufacturer
  - ▶ Observe the shelf life of the fuel according to the supplier.
  - ▶ Observe the engine operating manual.
- 

**NOTICE!****Excessive heat or moisture can destroy the device.**

- ▶ Always ensure that there is a good supply of air and heat removal.
  - ▶ Never operate the generator in rooms or narrow pits.
  - ▶ Never clean the device with the aid of a strong jet of water or high pressure cleaner.
  - ▶ Never allow water to find its way inside the generator.
-

## 4.4 Authorised operating personnel – qualifications and obligations

**Your Generators is a complex machine, the operation and maintenance of which requires exact knowledge of its functions and danger potentials. Therefore any work with or on the device, of any kind, may only be performed by authorised and instructed operating personnel.**

**Quite apart from the authorisation which the operating company of the device must issue, only such persons may operate or service the device who fulfil the following criteria. They are designated in this operating manual as operating personnel.**

The authorised operating personnel must:

- be of age.
- be trained in First Aid and be able to provide it.
- be familiar with the accident prevention regulations and safety instructions relevant to the Generators and be able to apply them.
- have read Chapter 4 , have understood the contents and are able to use and implement them in practice.
- be trained and instructed according to the rules of conduct in the case of malfunctions.
- have the physical and mental abilities to carry out their responsibilities, tasks, and activities on the Generators.
- be trained and instructed in their responsibilities, tasks and activities on the Generators.
- have understood the entire technical documentation concerning their responsibilities, tasks and activities on the Generators and be able to implement these in practice.

## 5 Checking the electrical safety

**Checking of electrical safety requires different measures to be taken which may only be undertaken by respectively authorised personnel. In doing so the respective, pertinent VDE provisions, EN and DIN standards, in their respectively valid versions, must be observed.**

One must, in particular, not use defective or damaged consumers, cable connections and plug connectors (power consuming equipment). There must be checking for an orderly condition at regular intervals (see Tab. 5-1 )

Your generator is designed for use with one (1) individual electrical power consuming equipment. Hereby the protective conductor system of the attached power consuming equipment takes over the function of the potential equalization device. The terminal (Fig. 6-4 -9) is connected with this Potential equalization device connected. It is not necessary to earth the generator.

In addition to the details given above, the electrical safety of the generator is to be checked by a qualified electrician at regular intervals. The periods between testing must be established in such a way that the generator and all work equipment to be connected can, according to the general status of knowledge, operational experiences or on the basis of specific evidence, be safe to use in the period between the two inspections. (Examples in TRBS 1201, implementation instructions re §5 of BGV/GUV-V A3, BGI 594, BGI 608, Annex 2, recommendation of BGI/GUV-I 5090 "Repeated testing of mobile electrical equipment").



**NOTICE!**

**The operator is responsible for defining and adhering to the test intervals . Above all one must ensure observance of the respectively valid national regulations.**

**This responsibility also extends to any additional equipment installed in conjunction with the device.**

We recommend the following checks and deadlines as general guideline values:

When	What / how	Who
First start-up at the operating location	<ul style="list-style-type: none"> <li>• See chapter 7</li> <li>• Visual inspection for externally visible defects such as transport damage.</li> </ul>	Operating personnel
Start-up on a daily basis	<ul style="list-style-type: none"> <li>• See chapter 7.3</li> <li>• Visual inspection for signs of visible external defects (e.g. damaged insulation, connectors, cable; leaks, noise)</li> </ul>	Operating personnel
Retest at the latest once every six months	<ul style="list-style-type: none"> <li>• According to BGI/GUV-I 5090 "Repeated testing of mobile electrical equipment")</li> <li>• Sample test report according to DGUV information 203-032 *)</li> </ul>	Qualified electrician
*) Download as a text file under → <a href="http://www.dguv.de">www.dguv.de</a> Webcode: d138299		

Tab. 5-1 Recommended test intervals

## 6 Description of the device

### 6.1 Views

The following section provides an overview of the designation and location of the most important components of your generator. It is important to ensure that you are familiar with these in order to further understand the described functions and operating steps and to be able to perform these safely. Severe or deadly personal injuries can result and/or damage to the generator as well the attached power consuming equipment if these instructions are ignored.

In order to be in a position to clearly re-find named operating controls and components in the following descriptions and instructions, the individual views of the generator are designated throughout in a way which can be taken from the following figure.



Fig. 6-1 Views of the generator

①	Start side	②	Exhaust gas side
③	Maintenance side	④	Control side

## 6.2 Important components on the control and maintenance side



Fig. 6-2 Maintenance and control side components

1	Control panel	2	Tank cover
3	Transport grip	4	Maintenance flap

### 6.3 Important components on the start and exhaust gas side



Fig. 6-3 Exhaust gas and start side components

①	Filling level indicator	②	Cable pull starter
③	Exhaust gas outlet		

### 6.4 Control panel components

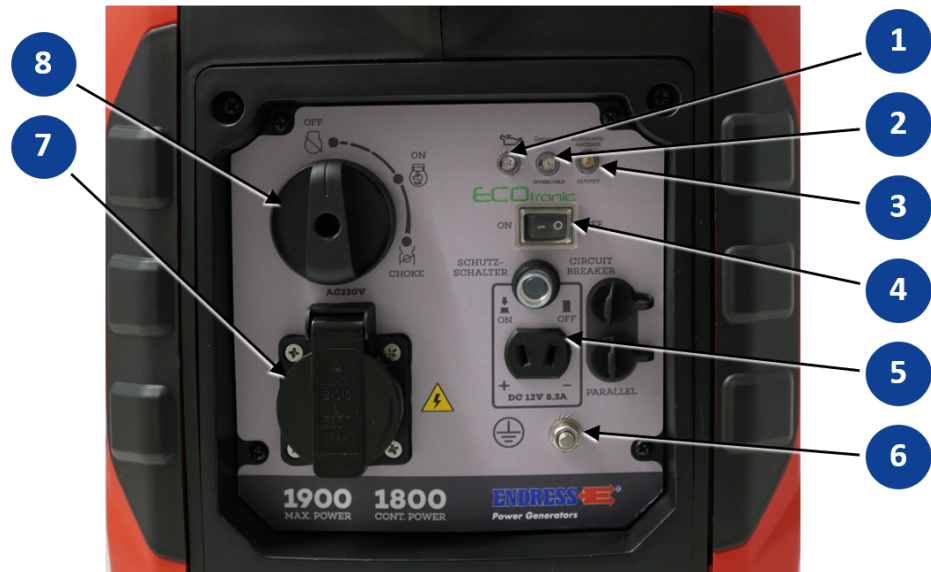

Fig. 6-4 Components on the control panel

1	Oil monitoring warning indicator	2	Overload alarm
3	Indicator light	4	ECOtronic On / Off
5	Battery recharging connection	6	Connection for Potential equalisation device
7	230V / 16A / 1~ Schuko socket	8	Multifunction switch

## 7 Commissioning

The following chapter describes the basic procedure for first time or repeated putting into operation of the generator. Follow the working steps described below when you put your generator into operation for the first time or restart it again after transporting it.



### NOTICE!

For start-up and operation of a generator on building and assembly sites, Deutsche Gesetzliche Unfallversicherung (DGUV) in DGUV Information 203-032, the May 2016 edition, requires observance of special protective measures and behaviour regulations.

We also urgently advise observance of relevant DGUV information under comparable operating conditions.

### 7.1 Transporting and preparing your generator

The following requirements must be fulfilled before you can transport the generator:

#### Conditions

- ✓ The installation area must have an even and load carrying substrate
- ✓ The generator is turned off
- ✓ The generator has cooled down
- ✓ The tank ventilation valve is in the "OFF" position



### WARNING!

#### Danger due to the device's heavy weight.

Risk of crushing through sliding or a falling machine

- ▶ Take note of the empty weight up to 22 kg.
- ▶ Only lift the device using the carrying handles.
- ▶ Raise / lower the device evenly.
- ▶ Walk slowly.



### NOTICE!

Leaking engine oil and operating fluids can contaminate the soil and groundwater.

- ▶ Ensure that the generator is transported horizontally and mounted.
- ▶ Make all efforts, at all costs, to prevent escaping of operating fluids.
- ▶ Dispose of contaminated soil immediately and according to regulations.

#### Transporting the generator

The generator is fitted with a fixed carrying handle so that you can lift it up or carry it over rough terrain.

1. Grasp the generator's fixed carrying handle.
2. Raise the generator evenly.
3. Carry the generator to the place of use.

4. Lower the device slowly and evenly.  
*The unit has been transported and positioned at its work site.*

## 7.2 Refuelling your generator

Proceed as follows to fit the generator's own tank: the generator.

### Conditions

- ✓ the generator is turned off
- ✓ the generator has cooled down
- ✓ there must be an adequate air supply and air removal
- ✓ all power consuming equipment must be disconnected or switched off



### **DANGER!**

#### **Leaking engine oil and fuel can burn or explode.**

A risk of suffering severe even deadly burns.

- ▶ Prevent engine oil or fuel from leaking out.
- ▶ Never open the tank cover during operation or when it is hot.
- ▶ Remove leaked operating fluids immediately and appropriately.
- ▶ Never use an additional starting aid.
- ▶ Smoking, naked flames and sparks are forbidden.



### **NOTICE!**

#### **Leaking fuel can contaminate soil and groundwater.**

- ▶ Take note of the residual quantity in the tank and its maximum filling capacity.
- ▶ Always bear in mind that the fuel gauge reacts only after a time delay.
- ▶ Fill the tank to a maximum of 95%.
- ▶ Always use a filling aid (e.g. funnel).



### **NOTICE!**

#### **Use of wrong or outdated fuel damages or destroys the engine.**

- ▶ Only use the fuel displayed on the sign (Tab. 3-1 ).
- ▶ Observe the possibly enclosed documentation for the fuel release of the engine manufacturer
- ▶ Observe the shelf life of the fuel according to the supplier.
- ▶ Observe the engine operating manual.

### Refuelling the generator

1. Unscrew the tank cover Fig. 6-2 .
2. Insert the filler nozzle into the filling opening.
3. Fill with fuel slowly and evenly.
4. Take note of the tank's fuel level indicator Fig. 6-3 as well as the fuel level at the filling opening to ensure that you do not overfill the tank.
5. Remove the filler nozzle.
6. Refit the tank cover.

*The generator is now refuelled.*

### 7.3 Starting the generator

Starting the generator for manual operation and with fuel supplied from its own tank is explained here.



#### **DANGER!**

##### **Leaking engine oil and fuel can burn or explode.**

A risk of suffering severe even deadly burns.

- ▶ Prevent engine oil or fuel from leaking out.
- ▶ Never open the tank cover during operation or when it is hot.
- ▶ Remove leaked operating fluids immediately and appropriately.
- ▶ Never use an additional starting aid.
- ▶ Smoking, naked flames and sparks are forbidden.



#### **DANGER!**

##### **Engine exhaust gases contain poisonous and partially invisible gases such as carbon monoxide (CO) and carbon dioxide (CO<sub>2</sub>).**

Risk of death due to poisoning or asphyxiation.

- ▶ Ensure that there is good ventilation during the whole period of operation.
- ▶ Only operate the generator in the open.
- ▶ Never direct the exhaust gases into rooms or pits.

#### **NOTICE!**

**Frequent brief operations and/or long operating times without a load will have a negative effect on the operational readiness and the generator's service life.**

- ▶ Try to avoid frequent brief operations, otherwise the starter battery will not be sufficiently charged and it might fail.
- ▶ Always ensure that the battery is well charged by prolonging the operating phase whenever necessary or by recharging externally.
- ▶ Avoid long operating times without a load.



Fig. 7-1 Starting the generator

**Conditions**

**Proceed as follows to start the generator manually directly from the device:**

- ✓ electrical safety has been checked (see Chapter 5 ).
  - ✓ there is enough fuel in the tank.
  - ✓ oil level is good (fill with engine oil before initial use, see Chapter 9.3.1 ).
  - ✓ there is an adequate air supply and air removal system.
  - ✓ all power consuming equipment is disconnected or switched off.
1. Disconnect all loads from the output side
  2. Turn the ECOtronic switch **2** into the "OFF" position.
  3. Put the air-release valve on the tank cover **3** into the "ON" position.
  4. Turn the multifunction switch **1** into the "Choke" position.
  5. With one hand hold the generator by the carrying handle and pull on the cable grip with the other hand **4** until you feel a resistance. Pull on the cable grip strongly.  
*The engine will start.*
  6. Turn the multifunction switch **1** slowly into the "ON" position after the engine has warmed up.

*The engine has started.*



**NOTICE!**

**Do not apply load to the generator immediately after a cold start.**

- ▶ Allow the generator engine to warm up for a few minutes before switching on a load when the generator has not been operating for more than eight hours (or for very low external temperatures).

**NOTICE!**

The automatic low-oil system will not let the engine start if the oil level is too low.

- ▶ First refill up to the engine oil level (see Chapter 9.3.1 ), before you restart the engine.
- ▶ The automatic low-oil system cannot stop the engine from being damaged due to a low oil level in all cases. Never start the engine without checking the oil level beforehand!

## 7.4 Connection of power consuming equipment

**DANGER!**

Mortal danger due to an electric shock if live parts are touched.

- ▶ Never operate the device if it is in a damaged condition.
- ▶ Never operate the electrical consumers and connecting cable (power consuming equipment) in a damaged condition.
- ▶ Never feed directly into existing networks that are already connected to a power source (e.g. power supplier, solar plant, etc.).
- ▶ Never operate the device with wet hands.

Proceed as follows to connect up a consumer to your generator:

**Conditions**

- ✓ The generator is started and brought up to operating temperature (see Chapter 7.3 ).
- ✓ All power consuming equipment is disconnected or switched off.

**Connecting up the consumers**

1. Fold up the splash guard for the relevant Schuko socket Fig. 6-4 on the control panel.
2. Insert the plug from the power consuming equipment that is to be connected up all the way into the socket until it stops.

*The consumer is now to the generator and ready to use.*

**NOTICE!**

Do not exceed the generator's maximum power output of 1,800 W when selecting the power consuming devices.

Take note of the fact that certain consumers (e.g. circular saws, blowers, etc.) can significantly exceed their nominal output through the increased start up current during starting. Details can be found in the consumer's operating manual.

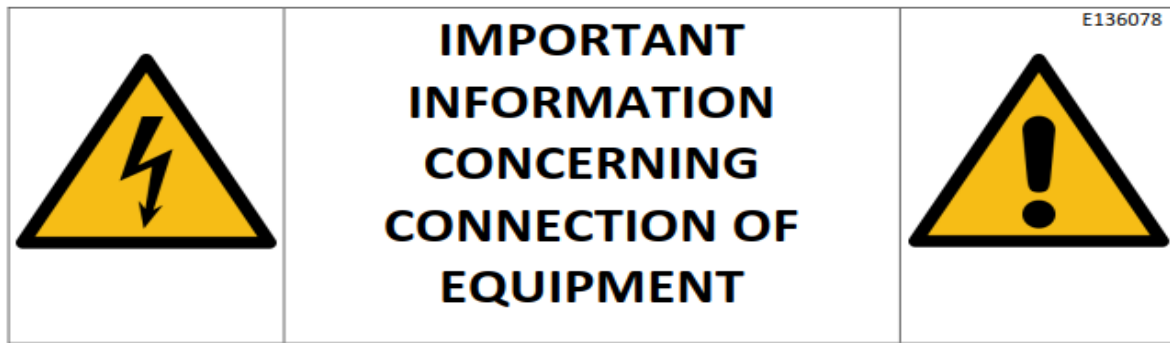

Your generator is designed for mobile use and according to the protective measure

**protective separation with equipotential bonding  
according to DIN VDE 0100-551:2017-02 (H 60364-5-551 + A11:2016-05)**

. This differentiates between commissioning undertaken by a trained electrician and that undertaken by an (electrically) untrained person. There are two options for use for the electrically untrained person:

**1. connection of a single piece of equipment to the generator**

In this case it is not necessary to check the electrical safety (see Chapter “Electrical safety“ in the operating instructions) beyond the protective measures. The protective conductor of the ground contact socket assumes the function of the potential equalisation line. **This case expressly excludes use of a power distributor (multiple socket).**

**2. connection of one or more pieces of equipment to the generator**

In this case the above-mentioned standard requires one of the following additional protective measures:

- a) protective separation with an insulation monitoring device (IMD) and automatic shut-off
- b) protective separation with residual current protective (RCD) and automatic shut-off

In doing so one RCD or PRCD must be used per power socket or circuit. For 3-phase networks we recommend use of an RCD Type B.

<p>Publication date December 2017</p>		<p>Responsible person HWB</p>
---	--	-----------------------------------

## 7.5 Parallel working using two generators

Using the parallel connection ability of the ESE 2100 I, you can roughly double the output power through electrical connection of two ESE 2100 I generators.



### DANGER!

**Mortal danger due to an electric shock if live parts are touched.**

- ▶ Never operate the device if it is in a damaged condition.
- ▶ Never operate the electrical consumers and connecting cable (power consuming equipment) in a damaged condition.
- ▶ Never feed directly into existing networks that are already connected to a power source (e.g. power supplier, solar plant, etc.).
- ▶ Never operate the device with wet hands.



### DANGER!

**Electric shocks cause injury or death.**

- ▶ You can only operate two identical ESE 2100 I in parallel.
- ▶ Parallel operation of more than two ESE 2100 I is not permitted.
- ▶ Never remove the parallel connecting cable while the generator is operating.
- ▶ Never connect consumers to the parallel connection socket.
- ▶ Only connect the original parallel connecting cable to the parallel connection socket.



Proceed as follows to connect a parallel connection to the generator:

#### Conditions

- ✓ Two identical ESE 2100 I generators with a parallel operation socket are available  ready to operate.
- ✓ A connected battery charging cable is disconnected.
- ✓ All power consuming equipment is disconnected or switched off.

**Connecting up the consumers**

1. Place both generators next to each other in such a way that air supply and removal are not impaired.
2. Connect the parallel connection cables to the parallel connection sockets on both generators ② .
3. Ensure that the parallel connecting cable does not get disconnected during parallel operation.
4. Start both generators one after the other (see 7.3 Starting the generator).
5. Allow the generators to warm up until both are running evenly at a stable rpm with a pressed in choke lever.

*Parallel operation has been established.*

*You can now connect a consumer with a high power consumption to a protective contact socket.*



**NOTICE!**

**When selecting the consumable in parallel operation, do not exceed the generator's maximum power output of 3,600 W.**

**Take note of the fact that certain consumers (e.g. circular saws, blowers, etc.) can significantly exceed their nominal output through the increased start up current during starting. Details can be found in the consumer's operating manual.**

## 7.6 Turning off your power generator

**Proceed as follows to switch off the generator:**

**Conditions**

- ✓ the attached power consuming equipment is disconnected or switched off.



**CAUTION!**

**Certain surfaces on the device can get very hot whilst it is running.**

Risk of burns

- ▶ Never touch any engine parts (in particular the exhaust system) for a few minutes after ceasing operation.
- ▶ Always leave hot engine parts to cool down before touching them.

**Switching the generator off**

1. Continue to run the engine without load for about two minutes.
2. Turn the ECOtronic switch ② .
3. Put the multi-switch Fig. 7-1 - ① into the "STOP" position.  
*The engine comes to a standstill and the generator is switched off.*
4. Turn the air-release valve on the tank cover Fig. 7-1 - ① back into the "OFF" position.

*The generator is switched off and secured.*

**DANGER!****Explosion hazard due to escaping fuel or fuel vapours.**

A risk of suffering severe even deadly burns.

- ▶ After stopping the generator, close the fuel valve (fuel feed) as soon as possible.
- ▶ Close the fuel valve (fuel feed) at the latest after ceasing to use the device. **BEFORE** transport.

## 8 The device in-use

### 8.1 ECOtronic (idle down)

Your Generators is fitted with an ECOtronic function. Fuel consumption and emissions will be reduced when the ECO mode is activated, as the engine speed is automatically adjusted to match the power requirement of the connected consumer. This also leads to a reduction in the noise level. As the power requirement increases, the engine speed will also increase to the same extent and this ensures trouble-free operation of the connected consumer. The electronics raise the engine speed again as soon as the connected power consuming equipment is switched on in order to make the full output available.

#### NOTICE!

**Always switch the ECOtronic off before you operate a very powerful consumer. The engine speed will increase up to nominal speed and provide full power without any delay when you turn on the consumer.**

Proceed as follows to run your Generators in ECO mode:

#### Conditions

- ✓ Generator is ready for operation
- ✓ The generator is started (see Chapter 7.3 )

#### Switching on ECOtronic

**Switch the idle engine speed reduction as follows:**

1. Turn the rocker switch Fig. 7-1 ② into the "I" (ON) position.

*Idle down is activated. The engine speed will drop significantly when a consumer is being run at a low power or is switched off.*

#### Turning off ECOtronic

**Switch the idle down off as follows:**

1. Turn the rocker switch Fig. 7-1 ② into the "0" (OFF) position.

*Idle down is switched off. The drive motor's speed increases to nominal speed (see Chapter 13 Technical data).*

## 8.2 Charging the batteries

The ESE 2100 I DC connection delivers a DC current of 12V / 8A and this gives you the option to also charge a 12V lead battery.



### DANGER!

**Mortal danger due to an electric shock if live parts are touched.**

- ▶ Never operate the device if it is in a damaged condition.
- ▶ Never operate the electrical consumers and connecting cable (power consuming equipment) in a damaged condition.
- ▶ Never feed directly into existing networks that are already connected to a power source (e.g. power supplier, solar plant, etc.).
- ▶ Never operate the device with wet hands.



### DANGER!

**Electric shocks cause injury or death.**

- ▶ Explosive hydrogen gas may escape during the charging process. Make sure that neither sparks nor an open flame may occur in the vicinity of the battery and the power generator during the charging process.
- ▶ Only charge the battery at well ventilated locations.
- ▶ Battery acid may harm the eyes and clothing. Avoid any contact and proceed with extreme caution.

Proceed as follows to connect a battery to the generator:

#### Conditions

- ✓ The device should be fully warmed up.
- ✓ The ECOtronic switch is switched into the "OFF" position.

#### Connecting up the battery

1. Connect the red positive terminal to the positive terminal of the battery.
2. Insert the 2-pin connector of the 12V charging cable into the 12V socket (Fig. 6-4 Components on the control panel-)
3. Connect the black negative terminal to the negative terminal of the battery

*The battery is charging.*

The 12V circuit breaker might trip out if a high capacity battery or a defective one or a fully discharged battery is being recharged. The circuit breaker can be switched on again by actuating the pressure head.

#### disconnecting the battery

1. FIRST disconnect the black negative terminal from the negative terminal of the battery.
2. Remove the 2-pin connector of the 12V charging cable from the power generator.
3. THEN disconnect the red positive terminal from the positive terminal of the battery.

*The battery is disconnected and charged.*

## 9 Maintenance

Generators maintenance is described in this section. It may only be performed by qualified specialist personnel.

Maintenance and repair which is neither described in this operating manual nor in the possibly also delivered operating and maintenance instructions may only be undertaken by authorized service personnel from the manufacturer.

### 9.1 Maintenance plan

Maintenance work on your generator must be performed periodically in order to secure its readiness to use and reliability over a long period. This work is only to be undertaken by trained specialist personnel. Contact your dealer or our

service hotline at: +49 7123 9737-44

service@endress-stromerzeuger.de



**NOTICE!**

Please note that, in the case of a concluded warranty agreement, you will lose all rights to make claims if your generator is not serviced according to manufacturer regulations.

You can find an overview of the time plan and scope of the required maintenance work in the following maintenance schedule.

Maintenance work		Maintenance interval according to time or operating hours [h]			
Item	Maintenance step	Daily / 8 h	After 1 month / 20 h	every 3 months or 50 h	annually every 100 h
Electrical safety	Check	X			
Engine oil	Check fill level	X			
	Change			X	
Air filter	Check	X			
	Clean; replace if necessary		X		
Spark plug	Check the electrode gap, clean; change when necessary				X
Valves	Check; adjust if necessary				X
Spark catcher	Check; clean if necessary			X	
Tank and filter	Cleaning				X
Fastening and threaded joints		X	X		
Maintenance work should be performed by your service partner.					

Maintenance work		Maintenance interval according to time or operating hours [h]			
Item	Maintenance step	Daily / 8 h	After 1 month / 20 h	every 3 months or 50 h	annual-ly every 100 h
Fuel lines	Check for cracks and damage; replace if necessary				X
Check the protective conductor connection		once every 2 years			
Maintenance work should be performed by your service partner.					

Tab. 9-1 Generator maintenance plan

## 9.2 Maintenance work

Only authorised personnel are allowed to carry out maintenance tasks. Carry out all of the maintenance work listed in the maintenance plan according to the instructions.



### CAUTION!

**Certain surfaces on the device can get very hot whilst it is running.**

Risk of burns

- ▶ Never touch any engine parts (in particular the exhaust system) for a few minutes after ceasing operation.
- ▶ Always leave hot engine parts to cool down before touching them.

## 9.3 Engine oil

The drive motor for your generator, like every internal combustion engine, requires the required engine oil for cooling and inner cooling. It is also important to use the correct oil, both for refilling and changing oil, and to observe the prescribed maintenance intervals.

When refilling or changing the oil, always use a commercially available multi-grade oil with a viscosity of SAE SJ 15W-40 for four stroke engines as is used in car engines. This applies for use of a generator in temperate climates. At very low or very high outside temperatures it may well be necessary to use an engine oil of another viscosity.

### 9.3.1 Checking the oil level

Your generator is fitted with an oil lack automatic switching off system to avoid engine damage occurring due to a low engine level. It has two functions:

- 1) It prevents the engine from starting with an insufficient engine oil level
- 2) it switches off the drive motor when the engine oil level falls below the minimum value while operating.

If the automatic switch-off has detected a lack of oil, this is displayed by lighting up of the yellow 7.3  warning light. In order to avoid delays and interruptions during operation, check the engine oil level before every putting into operation.

#### Conditions

Ensure that the following prerequisites are met before you check:

- ✓ ensure that the generator is mounted horizontally.

- ✓ wait after previous operation for about five minutes before checking until the engine oil has gathered again in the oil sump to obtain a correct measurement.



**CAUTION!**

The engine and operating equipment on the generator can get very hot while running.

Risk of burns

- ▶ Never touch any engine parts (in particular the exhaust system) for a few minutes after ceasing operation.
- ▶ Allow the engine to cool off for at least five minutes before changing or checking the engine oil.



Fig. 9-1 Checking and changing engine oil

**Checking the oil level**

1. Open the maintenance flap **1** using a suitable screwdriver
2. Loosen the yellow screw plug **2** and remove it from the filling opening. **ATTENTION!** The screw is wetted with oil.
3. The attached oil dipstick shows the oil level in the engine.

*The oil level has been checked.*

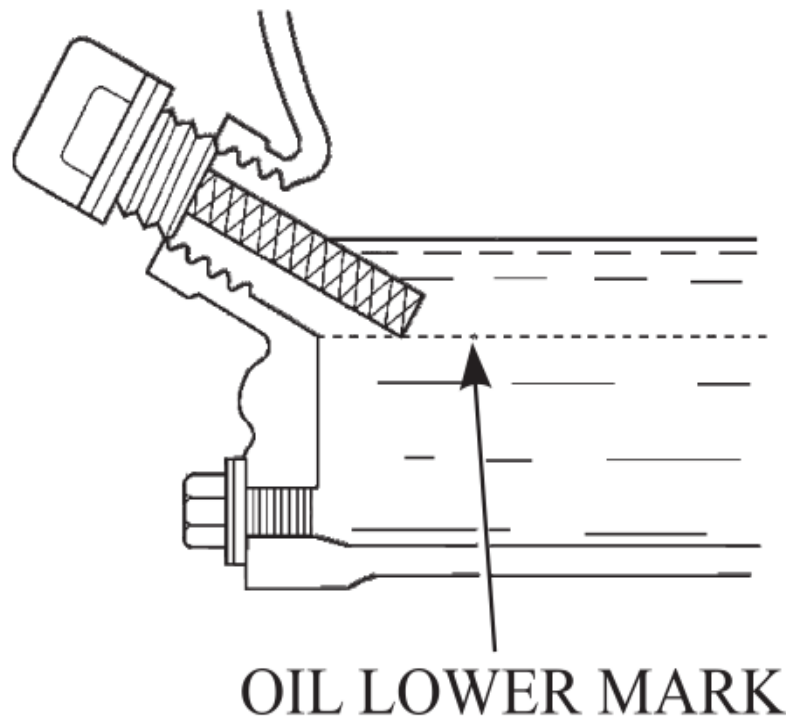

Fig. 9-2 Optimal engine oil level

### 9.3.2 Refilling with engine oil

Top up the oil if you notice that there is too little engine oil in your generator when you check the oil. The automatic low oil shut-off prevents the generator from starting until enough engine oil has been added. Please note that the oil filling capacity is 0.4 litres.

#### Conditions

Ensure that the following conditions are met before you refill with engine oil:

- ✓ ensure that the generator is mounted horizontally.
- ✓ wait after previous operation for about five minutes before checking until the engine oil has gathered again in the oil sump to obtain a correct measurement.



#### CAUTION!

**The engine and operating equipment on the generator can get very hot while running.**

Risk of burns

- ▶ Never touch any engine parts (in particular the exhaust system) for a few minutes after ceasing operation.
- ▶ Allow the engine to cool off for at least five minutes before changing or checking the engine oil.

#### Refilling with engine oil

If the oil level is too low, instigate the next steps to correct the level.

1. Make ready the engine oil to top up with.
2. Open the maintenance flap Fig. 9-1 - **1**.
3. Undo the locking screw Fig. 9-1 - **2**.

4. Put the filling funnel into the engine's open filling port.
5. Just put a small amount of engine oil in the funnel and wait until the oil has drained down completely.
6. Remove the filling funnel.
7. Compare the oil level against the image Fig. 9-2 Optimal engine oil level (at the bottom right) and repeat steps 2 to 4 until the engine oil has reached the top of the filling opening.
8. Clean the locking screw with a clean cloth and turn it clockwise to the stop in the filling opening.

*The oil level has been replenished.*

### 9.3.3 Changing the engine oil

The engine oil in your generator needs changing after the first 20 operating hours, but no later than one month, to remove all abrasion material produced during the break-in period. Subsequent oil changes should be made every 50 operating hours or after three months at the latest (see Maintenance schedule 9.1).



**CAUTION!**

**The engine and operating equipment on the generator can get very hot while running.**

Risk of burns

- ▶ Never touch any engine parts (in particular the exhaust system) for a few minutes after ceasing operation.
- ▶ Allow the engine to cool off for at least five minutes before changing or checking the engine oil.

**Conditions**

Ensure that the following prerequisites are met before you change the engine oil:

- ✓ Place the generator in such a way that a suitable catching pan can be placed under the oil drain screw.
- ✓ ensure that the generator is mounted horizontally.
- ✓ wait after previous operation for at least five minutes before changing the oil to allow the oil to flow into the oil sump and for the engine oil to cool off.



**NOTICE!**

**Leaking engine oil contaminates the soil and groundwater.**

- ▶ Use a suitable oil catching receptacle.
- ▶ Old oil is a special waste and may only be disposed of over suitably qualified collection points.

**Draining off old oil**

1. Loosen the three screws in the cover on the start side and then remove it.
2. Place a suitable oil collection container under the generator.
3. Loosen the yellow screw plug Fig. 9-1 **1** and remove it from the filling opening. **ATTENTION!** The screw is wetted with oil.
4. Ensure that the collection container is placed correctly.
5. Tip the generator slightly in the direction of the collection container to allow draining off of the old oil.

*The old oil flows through the housing opening into the collection container.*

6. If the old oil has completely drained out, close the opening using a new oil drain screw.
7. Dispose of the old oil according to the regulations.

*The old oil has been drained off.*

### Refilling with new engine oil

1. To refill with fresh engine oil, proceed as described in Chapter Fig. 9-1 . Observe the instructions to select a suitable oil. The amount of oil needed is 0.4 litres.
2. Use the three screws to reattach the cover.

*The engine oil has been changed. Your generator is ready to use again.*

## 9.4 Maintenance of the air filter

**The air filter insert must be cleaned every 100 operating hours and also changed if necessary. Operation with a dirty filter increases fuel consumption, pollutant emissions and engine wear. A damaged or missing air filter can destroy the engine.**

Proceed as follows to service the air filter.

### Conditions

- ✓ The generator is switched off.
- ✓ The engine is cooled down sufficiently.
- ✓ A new air filter insert is ready to use.

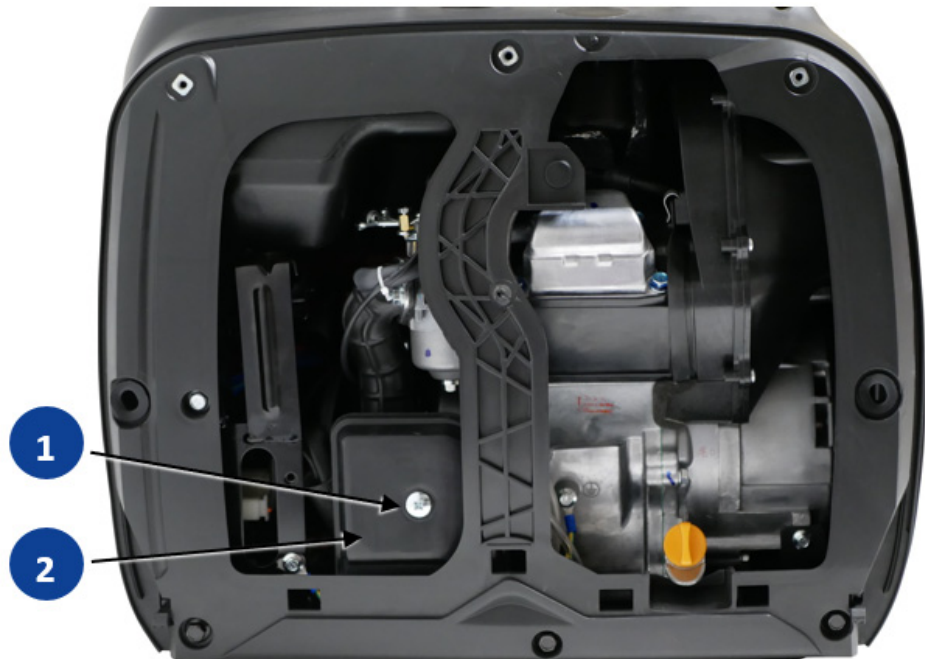

*Fig. 9-3 Air filter behind the maintenance flap (removed)*

### Change the air filter insert

1. Loosen the three large screws so that you can remove the cover on the maintenance side and access the air filter housing.
2. Undo the fastening screw **1** and pull off the air filter cover **2** .
3. Remove the air filter insert and decide after making an appraisal:
  - a) in a case of minor soiling remove loose dirt particles from the air filter insert.
  - b) in a case of strong soiling use a new air filter insert.

4. Clean the air filter housing and cover, in this case in particular the suction opening.
  5. Protect your hands from contact with engine oil.
  6. Apply a few drops of new engine oil to the cleaned or new air filter insert.
  7. Knead the air filter insert in order to distribute the oil evenly into the foam.
  8. Wring out the air filter insert strongly afterwards to remove excessive oil.
  9. Insert the air filter insert into the air filter housing.
  10. Carefully place the air filter cover **2** on the air filter housing and fasten it on using the screw **1**.
  11. Refit the cover and tighten up the three screws to hold it in place.
  12. Dispose of a soiled air filter insert according to regulations.
- Maintenance of the air filter is complete.*

### 9.5 Spark plug maintenance

The spark plug must be checked every 100 operating hours, at least however once a year, and replaced if necessary. Wrong adjusted, soiled or worn spark plugs can have a negative effect on the starting behaviour, engine running, fuel consumption and pollutant emissions.



**NOTICE!**

When replacing the spark plug, only use the following types:

- ▶ TORCH A5RTC

Proceed as follows to carry out spark plug servicing.

**Conditions**

- ✓ The generator is turned off
- ✓ The engine is cooled down sufficiently
- ✓ A new spark plug is ready to use

**Tools needed**

- A spark plug wrench (in the scope of delivery)
- Setting gauge for the electrode gap

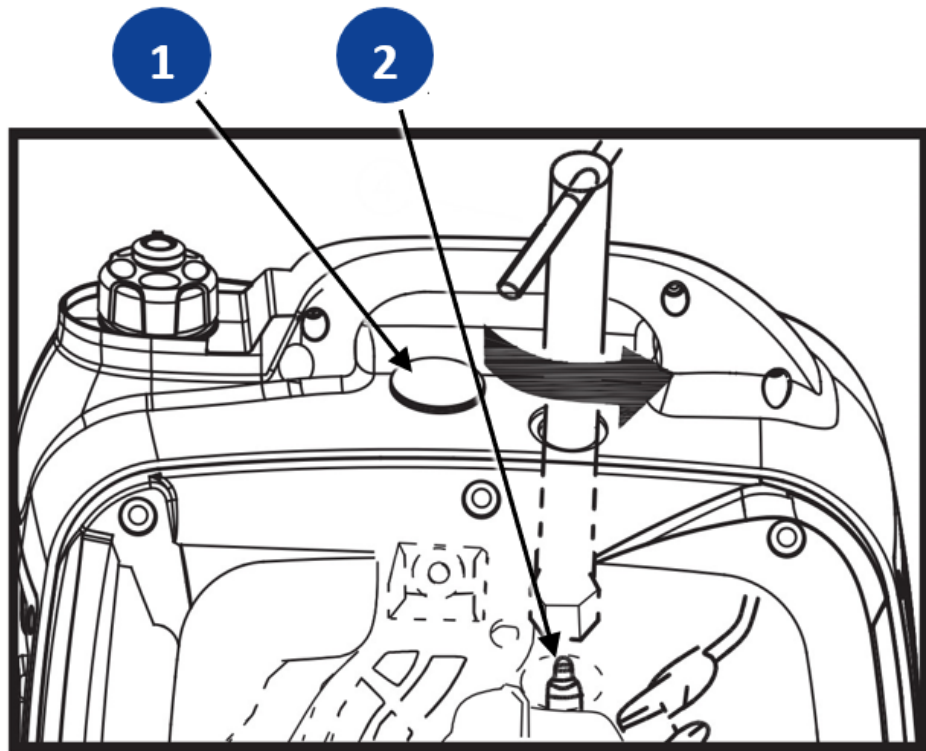

Fig. 9-4 Remove spark plug

- Remove spark plug**
1. Loosen the three screws in the cover on the maintenance side and then remove it.
  2. Remove the cover **1** and then use the spark plug wrench to remove the spark plug.
  3. Pull the spark plug connector Fig. 9-4 off of the spark plug. To do this by always pulling it directly off of the plug, never by pulling the ignition cable!
  4. Place the spark plug wrench on the spark plug Fig. 9-4 and unfasten it by turning it anti-clockwise.

*The spark plug is removed and must now be assessed.*

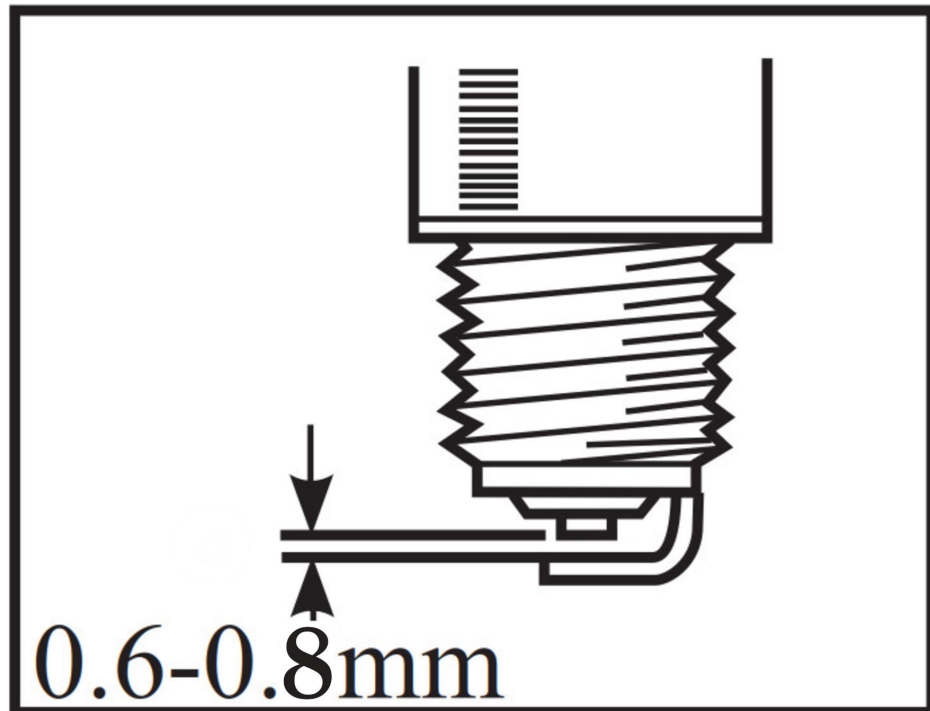

Fig. 9-5 Checking the spark plug

**Checking the spark plug**

1. Check the spark plug for damage and clean it using a suitable brush, if it can be used again.
2. Check the condition and gap of the electrodes, also when using a new spark plug. Adjust the gap to the correct value if necessary (see Fig. 9-5 Checking the spark plug).

*The spark plug is ready to be installed.*

**Installing the spark plug**

1. Turn the checked spark plug clockwise **by hand** into the spark plug thread in the engine. Fig. 9-4 Ensure that the spark plug is inserted without it tilting, so that the thread is not damaged.
2. Tighten the spark plug using the spark plug wrench supplied.
3. Press the spark plug connector firmly onto the spark plug.

*The spark plug has been serviced in an orderly manner.*

*The generator is ready to use.*

**9.6 Cleaning the spark screen**

**The spark screen prevents escaping of glowing exhaust particles and is located right next to the exhaust outlet. It must be disassembled every 100 operating hours and cleaned. The spark screen must be replaced if it is strongly soiled or damaged.**

Proceed as follows to service the spark screen:

**One has the required tool**

- a small slotted-head screwdriver
- Wire brush

**Conditions**

- ✓ The generator is switched off.
- ✓ The engine and particularly the exhaust system have cooled down.

**Servicing the spark screen**

1. Loosen the six screws on the exhaust gas side.
2. Loosen the screw for the spark screen's clip.

3. Remove the securing clip from the spark screen.
4. Use a small slotted-head screwdriver to get the spark screen out of the exhaust gas outlet and then pull it out completely.  
*The spark screen is removed.*
5. Assess the condition of the spark screen and replace it if it is damaged.
6. If the spark screen does not need replacing, clean it thoroughly with the aid of the wire brush.
7. Perform steps 1 to 3 in reverse order in order to fasten the spark screen again.

*The spark screen is serviced. The generator can be put into operation again.*

## 9.7 Cleaning the power generator

Keep your Generators clean and dry to ensure safe use at all times and a long service life. Never expose your Generators to extreme weather conditions, environments with heavy dust and dirt, moisture or aggressive vapours.



### **DANGER!**

#### **Danger of current flow if water enters.**

Mortal danger from electrocution

- ▶ Never clean the device during active operation.
- ▶ Never clean the device under running water or by using a high pressure cleaner.

### **NOTICE!**

**Never use a garden hose to clean the Generators. Water can get inside through the cooling slots and damage the device.**

Proceed as follows to clean the Generators:

- Use a soft brush to remove any dirt or oil.
- Use a damp cloth to clean the outside of the device
- Inspect all ventilation and cooling slots to ensure that they are clean and free.
- Use a clean cloth or an air compressor (pressure must not exceed 1.7 kPa / bar) to thoroughly dry the device.

## 10 Storage

It is important to store the device at a suitable storage location as soon as your generator is no longer being used.

- The storage location must be roofed and must not be subjected to standing water, aggressive vapours or soiling as well as major accumulation of dust.
- Protect your device with a cover made out of breathable material.
- Ensure that the storage temperature and air humidity lie within the specified limits (see Technical data).



### **NOTICE!**

**Due to the limited shelf life of the different operating fluids, it is important for decommissioning for more than one month that additional measures for storage are taken. While doing this observe the instructions given in the attached operating and maintenance instructions from the engine manufacturer.**

## 11 Disposal

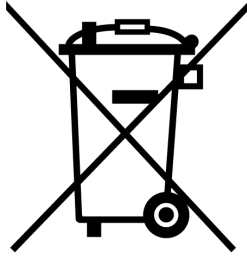

Your device, which is an electrical or electronic device, is subject to European Directive 2012/19/EU (“WEEE directive”) which is implemented in Germany in national law through the decree regulating the use of dangerous substances in electrical and electronic equipment (ElektroStoffV). This regulates disposal and use of recycling waste electrical equipment. The adjacent icon with a crossed-out wastebasket on your device states that it must not be disposed of in the household waste at the end of its service life.

As a private end-user (a so-called b2c customer) there are free collecting points (recycling centre) near you for electrical equipment as well as possible also other collection points available for reuse of devices. The addresses can be obtained from your city or communal authority. In as far as the old electrical and electronic equipment contains personal data, you are responsible yourself for its deletion before giving it back.

Pure b2b devices (devices which, for appropriate use, or exclusively are only used the commercial area) must not be disposed of over public collecting points in Germany and further EU countries. Speak to your authorised ENDRESS generator dealer about handing back your recycling waste electrical equipment. The dealer is also your point of contact for any differing regulations on the respective country of deployment. There are also possible agreements in the purchase contract to observe.

Please observe the pertinent environmental protection regulations when disposing of the old oil. We recommend bringing the oil in a closed container to an old oil collection centre for disposal. Never put used engine oil in the domestic waste. Storage or introduction of old oil into nature is associated with very high fines.

An inappropriately disposed of battery can greatly damage the environment. Give back your old battery directly free of charge to your dealer when purchasing a new one.

Always observe the valid local regulations and laws concerning correct disposal of all old parts and operating materials. Please contact your ENDRESS service partner for a replacement.

## 12 Troubleshooting

The following table is an aid for you to use in a case where faults arise during use. Based on experience a number of malfunctions can already be removed by operating personnel or the possible causes limited. In all other cases contact your service partner as described in the table. The same applies for faults which are not listed in the table.

If a fault cannot be removed using the remedies described, shut down your generator and secure it against further use. Contact your service partner and give him an explanation, not only of the symptoms but also the possible causes which you can already exclude based upon the table. In this way you are supporting the diagnostic process so that the fault can often already be identified over the telephone or through written exchange with our specialists.



**NOTICE!**

The following table does not make any claims to completeness and does not mention any faults which can be caused by operating error.

- In order to avoid operating errors, please exactly follow the instructions in the existing and delivered documentation.

Malfunction	possible cause	Correction
The engine turns but does not start.	Fuel level too low	Top up with fuel
	The fuel filter is clogged.	Replace the fuel filter.
	The fuel is unusable due to overaged	Carburettor cleaning, clean the fuel tank and replace the fuel
	Spark plug connector detached	Firmly put the spark plug connector in place again
	The spark plug is very dirty or defective	Clean the spark plug and adjust or replace it
	Engine oil level too low (oil lack automatic switch-off)	Bring the engine oil level up to the maximum
The engine does not rotate	Insufficient compression	Contact your service partner
	The starter battery is discharged or defective (only for electrical starting)	Clean a corroded battery pole Check the starter battery and charge it or replace it
	Starter defective	Replace the starter
	Engine mechanically blocked (also for starting by hand)	Contact your service partner

Malfunction	possible cause	Correction
The engine starts but stops again shortly afterwards	Fuel level too low	Top up with fuel
	The fuel filter is clogged.	Replace the fuel filter.
	Engine oil level too low (oil lack automatic switch-off)	Bring the engine oil level up to the maximum
	Spark plug connector detached	Firmly put the spark plug connector in place again
	Tank ventilation (tank cover) blocked	Clean ventilation holes
The generator is running but there is no (output) voltage at the socket	Overload protection triggered (operating status display lights up red)	Connect up a piece of power consuming equipment with a low output
	The alternator or cabling is defective	Contact your service partner
	The engine speed regulator is wrongly adjusted or defective	Contact your service partner
The generator is running but the output voltage is outside of tolerance	The electronic voltage regulator is wrongly adjusted or defective	Contact your service partner
	The load of the attached power consuming equipment is too high	Connect up a piece of power consuming equipment with a low output
The power output remains significantly below the nominal output	Operation under extreme climatic conditions	Adapt to the climatic conditions or stop the generator
	The generator has been poorly serviced	Perform maintenance work
	The generator has reached its wear limit	Contact your service partner
The engine smokes	The engine oil level is too high	Draining off excess engine oil
	The air filter insert (paper) is dirty or contaminated with oil	Clean the air filter insert or replace it
	The air filter insert (foam) is dirty	Clean the air filter insert and re-oil it
The generator is running at a high speed and with strong voltage fluctuations	The engine is still in the warm up phase	Wait until the engine has reached its operating temperature
	The carburettor is wrongly adjusted or defective	Contact your service partner
	The engine speed regulator is defective	Contact your service partner

Tab. 12-1 Troubleshooting

Please contact our customer service for further fault diagnosis as well as procurement of original spare parts and wear parts at

**Tel. +49-(0)-7123-9737-44**

[service@endress-stromerzeuger.de](mailto:service@endress-stromerzeuger.de) or

[www.endressparts.com](http://www.endressparts.com) (see Chapter 15 )



## 13 Technical data

The following table contains the technical data for your generator.

Name	Value	Unit
	ESE 2100 i	
Generator model	synchronous	
Maximum output [[LTP]	1900	[W]
Continuous output [PRP]	1800	[W]
Nominal frequency	50	[Hz]
Nominal speed	3500 - 4600	[min <sup>-1</sup> ]
Nominal voltage ~1	230	[V]
Nominal current ~1	7.8	[A]
Weight (ready for use)	22	[kg]
Drive motor	4-stroke OHV cylinder	
Displacement	79	[cm <sup>3</sup> ]
Cooling systems	air-cooled	
Engine oil capacity (SAE SJ 15W40)	0.4	[l]
Tank capacity (lead-free regular grade fuel - at least ROZ95)	4.8	[l]
Fuel consumption (at a 75% load) <sup>1)</sup>	0.96	[l/h]
Running time (at 75% load) about <sup>1)</sup>	5	[h]
Dimensions L x W x H	498 x 293 x 467	[mm]
Sound pressure level at a distance of 7m L <sub>pA</sub> <sup>3)</sup>	65	[db (A)]
Sound power level L <sub>WA</sub> <sup>3)</sup>	90	[db (A)]
Generator's protection system	IP23	
<sup>1)</sup> An average value dependent upon the operating conditions and therefore not binding		
<sup>2)</sup> Measured at a distance of 1 m and a height of 1.6 m in accordance with ISO 3744 (Part 10)		
<sup>3)</sup> Measured in accordance with ISO 3744 (Part 10)		

Tab. 13-1 Power generator technical data

## 14 CE declaration

	<b>Original EU-Konformitätserklärung</b> Translation of the Original EC declaration of conformity Traduction de la déclaration CE de conformité originale Traducción de la declaración CE de conformidad original	
---	--	---

### Stromerzeuger Generating set, Groupe électrogène, Grupo electrogeno

Handelsbezeichnung Trade name Dénomination commerciale Nombre comercial	Artikel-Nr : Order-nr. Numéro d'article número del artículo
<b>ESE 2100I; ESE 2300I</b>	<b>110007; 110008</b>

erklärt in alleiniger Verantwortung, dass das oben genannte Produkt, auf das sich diese Erklärung bezieht, in Übereinstimmung mit folgenden einschlägigen Richtlinien und Normen steht:  
 declares under sole responsibility that the above mentioned product, to which this declaration relates, is in accordance with the following relevant directives and standards:  
 déclare sous sa seule responsabilité, que le produit mentionné ci-dessus auquel se réfère cette déclaration est conforme aux directives et normes pertinentes suivantes :  
 declara bajo su exclusiva responsabilidad que el producto antes mencionado al que se refiere esta declaración se ajusta a las siguientes directivas y normas pertinentes:

Angewandte Richtlinien und Verordnungen der EU <b>2006 / 42 / EG (machinery), 2014 / 30 / EU (EMC) 2011 / 65 / EU (RoHS) 2000 / 14 / EG, 2005 / 88 / EG (noise emission)</b>	Angewandte Normen in der jeweils gültigen Fassung <b>DIN EN ISO 8528 EN 55012, EN 55014 DIN EN 50581 HD 60364-5-551 DIN EN 60204-1, DIN EN 60335-1</b>
---	---

einschließlich nachfolgender Änderungen und Ergänzungen  
and subsequent modification and integrations  
et aux modifications successives at intégrations  
y sucesivas modifcicas y integraciones

Gemessener Schalleistungspegel $L_{WA}$ Measured sound power level $L_{WA}$ Niveau de puissance sonore mesuré $L_{WA}$ Nivel de potencia sonora medida $L_{WA}$	Garantierter Schalleistungspegel $L_{WA}$ Guaranteed sound power level $L_{WA}$ Niveau de puissance sonore garanti en $L_{WA}$ Nivel de potencia sonora garantizada $L_{WA}$
88 dB(A)      Art.-Nr.: 110007; 110008	89 dB(A)      Art.-Nr.: 110007; 110008

Messverfahren entsprechend ISO 3744 (Teil 10)  
Measurement procedure according to ISO 3744 (part 10)  
Procédé de mesure selon ISO 3744 (partie 10)  
Procedimiento de medición según ISO 3744 (parte 10)

Bewertungsverfahren zur Feststellung der Übereinstimmung nach 2000/14/EG Anlage VIII (benachrichtigte Stelle):  
Evaluation procedure for the determination of compliance with 2000/14/EC Annex VIII (notified body):  
Procédé d'évaluation de conformité selon 2000/14/CE Annexe VIII. (organisme avisé):  
Procedimiento de evaluación para la determinación de la conformidad según 2000/14/CE Anexo VIII (organismo notificado):

Benannte Stelle zur Feststellung nach 2000/14/EG Anhang VIII  
Named body for assessment according to 2000/14/EC Annex VIII  
Organisme mandaté pour la certification selon la norme 2000/14/CE Annexe VIII  
Organismo notificado para la verificación según la Directiva 2000/14/CE, anexo VIII GB

Name und Anschrift der Person, die die technischen Unterlagen aufbewahrt  
Name and address of the person who keeps the technical documentation  
Nom et adresse de la personne qui garde la documentation technique  
Nombre y dirección del encargado de la documentación técnica

ENDRESS Elektrogeräteeu GmbH  
Neckartenzinger Straße 39  
D - 72658 Bempflingen

||  
verantwortlich  
authorized by  
le responsable  
el responsable

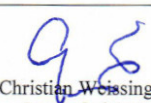
Bempflingen, 16.03.2021	 Christian Weissinger Geschäftsführer
-------------------------	--

E06/005-05

## 15 Replacement parts

Maintenance and replacement parts can be obtained quickly and easily from your responsible ENDRESS service partner or ENDRESS dealer. You can alternatively obtain support from our central customer service

by telephone: +49 (0) 71239737-44

by email: [service@endress-stromerzeuger.de](mailto:service@endress-stromerzeuger.de)

Have the item and serial number of your device ready for identification.

As a registered user you can obtain rapid and uncomplicated access to a range of services over our home page to obtain suitable original spare parts for maintenance and repair work. Using your internet browser please go to

<https://endressparts.com>

and click on the area “Documentation and replacement parts“.

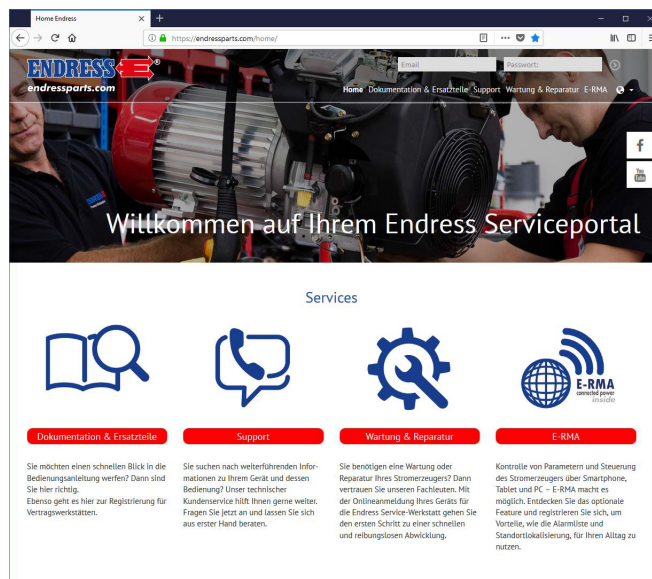
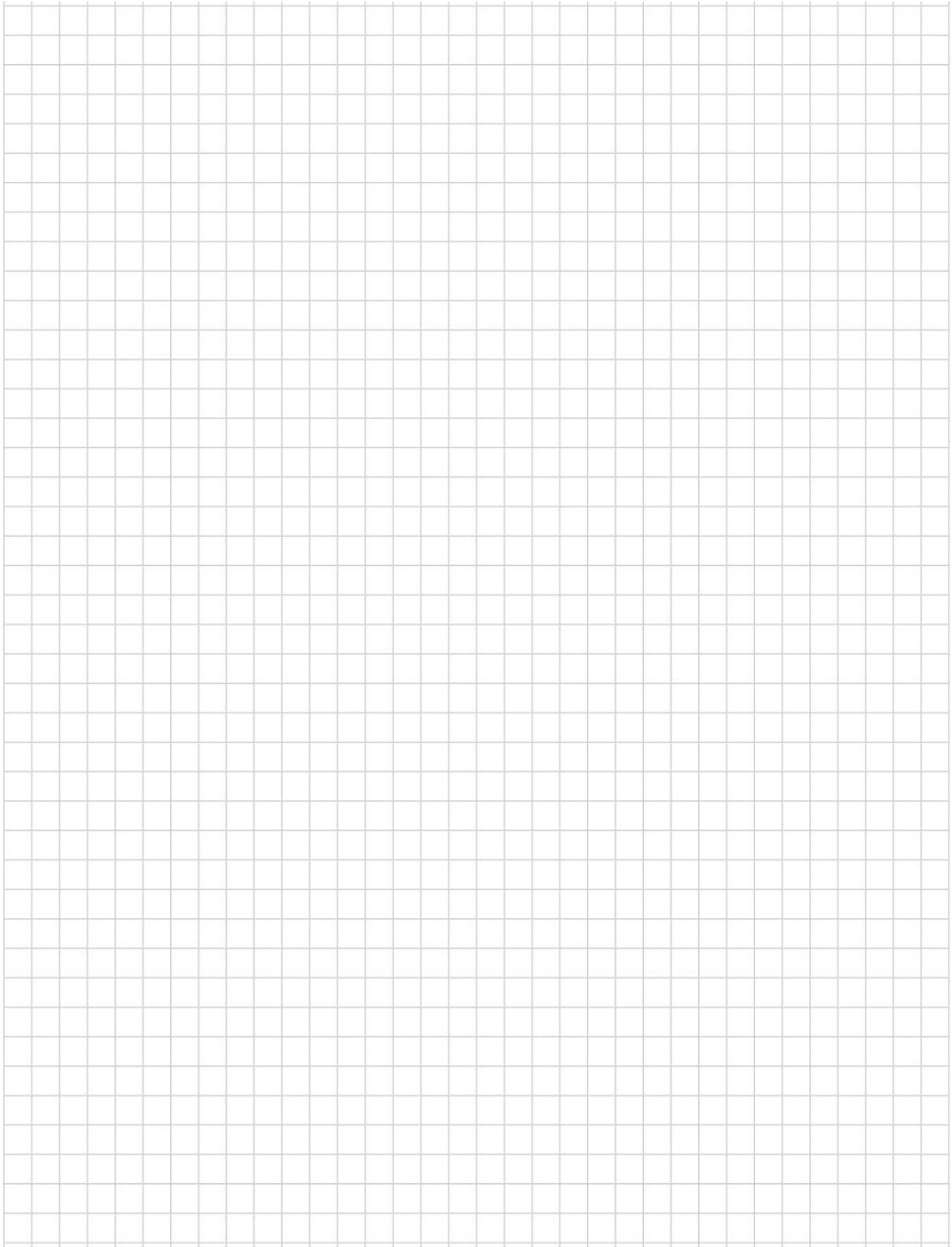
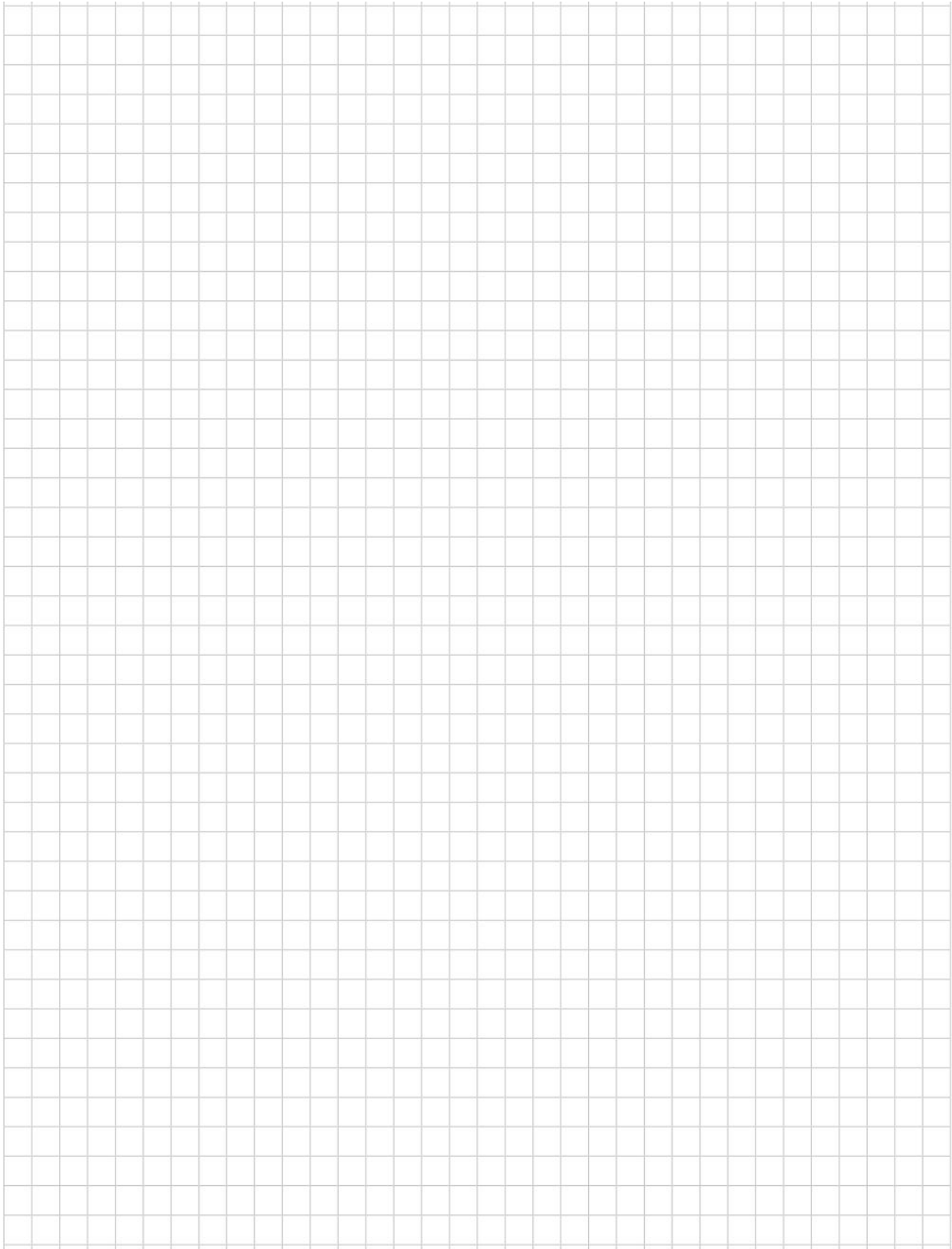

Fig. 15-1 Spare parts over [endressparts.com](https://endressparts.com)

**NOTES**



**NOTES**



**Keyword index****A**

Automatic low-oil system 32

**B**

Battery charging cable 12

**C**

Control panel 25

Control side 24

Customer service 56

**E**

ECO-mode economy circuit 27

Electrical safety 23

evaluated 17

Exhaust gas outlet 26

Exhaust gas side 24

Exhaust gases 19 30

**F**

Filling 29

Filling funnel 12

**H**

Home page 56

**I**

Imprint 2

included in the delivery 12

**L**

Label 13 13

**M**

Maintenance side 24

misuses 10

**O**

operating manual) 7

Operating personnel 17 22

own tank 29

**P**

Potential equalisation device 27

Potential equalization device 23

**S**

safety instructions 15

Safety symbols 15

sockets

Schuko 27

Standards

DIN EN ISO 12100 17

DIN EN ISO 8528-13 17

DIN ISO 3864 6

DIN VDE 82079-1 6

ISO 3864 17

ISO 7010 15

VDE 100, Part 551 10

standards

DIN EN 60204 17

Suction side 24

Switching off 35

**T**

the power supply companies 11

Transport grip 25

**U**

under the operator's obligations 23

**W**

Warning notices 17

WEEE directive 50



**Elektrogerätebau GmbH  
Neckartenzlinger Str. 39  
D-72658 Bempflingen, Germany**

Tel: +49 (0) 7123 /9737-0

Fax: +49 (0) 7123 /9737-50

Email: [info@endress-stromerzeuger.de](mailto:info@endress-stromerzeuger.de)

www: [www.endress-stromerzeuger.de](http://www.endress-stromerzeuger.de)

© 2022, ENDRESS Elektrogerätebau GmbH