

OPERATING INSTRUCTIONS

Article no: 161034

Wheel set



ENDRESS Elektrogerätebau GmbH
Neckartenzlinger Str. 39

D-72658 Bempflingen

Telephone: + 49 (0) 71 23 / 9737-0

Fax: + 49 (0) 71 23 / 9737-50

Email: info@endress-stromerzeuger.de

www: <http://www.endress-stromerzeuger.de>

Table of Contents

1. OVERVIEW..... 3

2. ASSEMBLY 4

3. REPLACEMENT PARTS..... 7

4. SERVICE 7

1. Overview



2. Assembly

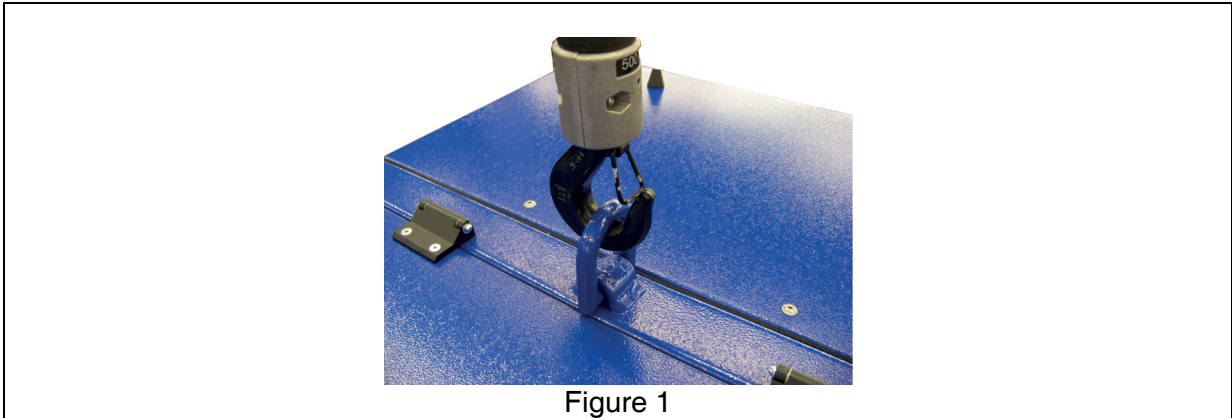

1. Raise the device using a suitable crane (to about 50 cm above the floor) (Fig. 1).
2. Push the holder for the shaft onto the axis (Fig. 2)

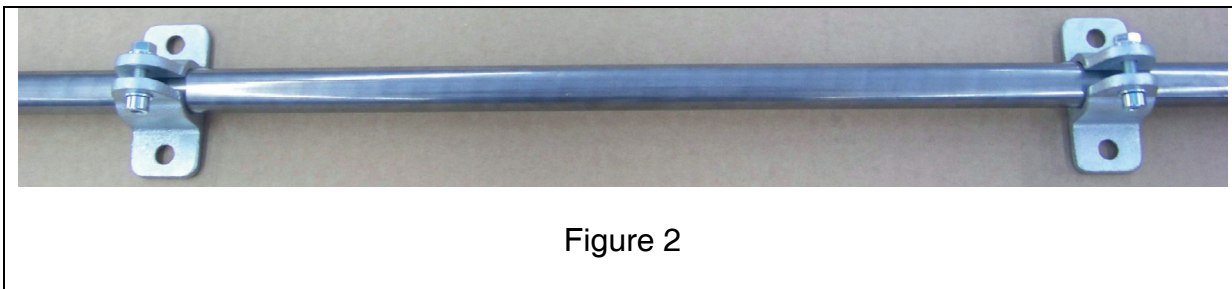

3. Mount the shaft on the underside of the generator and tighten screws (Fig. 3).

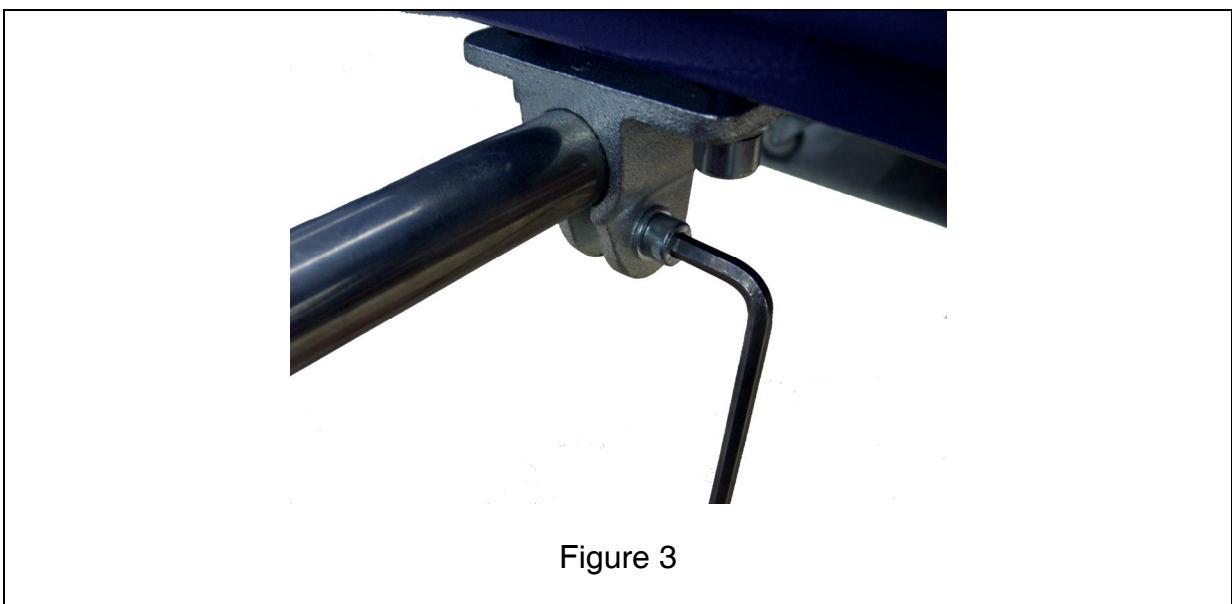

4. Adjust the shaft in such a way that it projects outwards by about 170 mm on both sides of the shaft holder (Fig. 4).



Figure 4

5. Fasten the shaft to the shaft holder (Fig. 3).
6. Remove the rubber buffers when using the wheel set (Fig. 4).
7. Push the inner adjusting ring onto the shaft and tighten (Fig. 5)



Figure 5

8. Push the wheels onto the shaft and fasten with the outer adjusting ring (Fig. 6)



Figure 6

9. Fasten the drawbar to the front side of the generator using four screws (Fig. 7).



Figure 7

3. Replacement parts

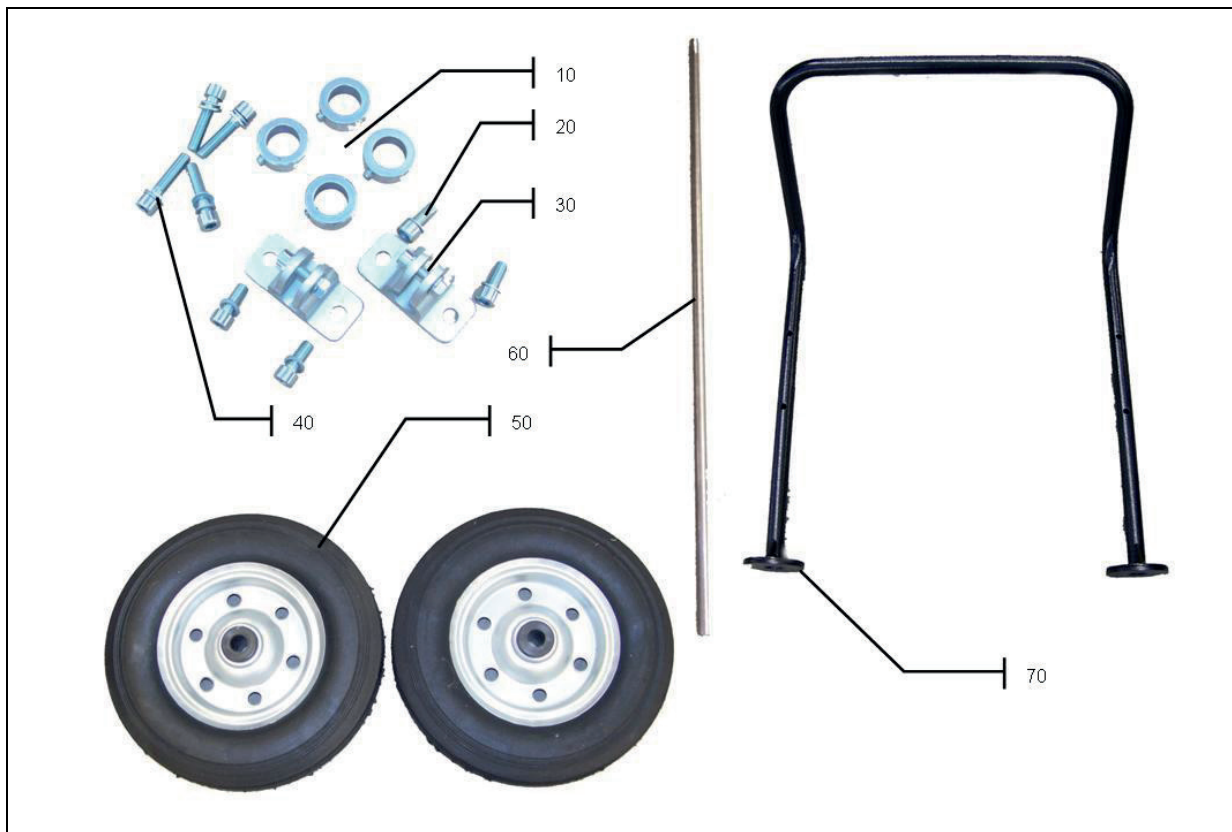

Item	Part number	Quantity	Article designation / manufacturer
10	E130793	4	Galvanised adjusting ring for a wheel set / Endress
20	E134143	4	Cap screw M 10 x 60 / Endress
30	E134140	2	Shaft bracket H/950/25 / Endress
40	E131339	4	Cap screw M 10 x 60 / Endress
50	E134142	2	WHELL for the wheel set / Endress
60	E134141	1	Shaft A25x1000 / Endress
70	E506787/91	1	Drawbar Sgr. Die.-Line / Endress

4. Service

The Service Hotline offers you assistance on questions about service as well for finding a current ENDRESS service station near you.

Phone +49(0) 7123 - 9737 - 0
 Fax +49(0) 7123 - 9737 - 50
 Email service@endress-stromerzeuger.de
 WWW www.endress-stromerzeuger.de